

CFE370 Series

Fiber Optic AlGaAs IREDS

13-3703A

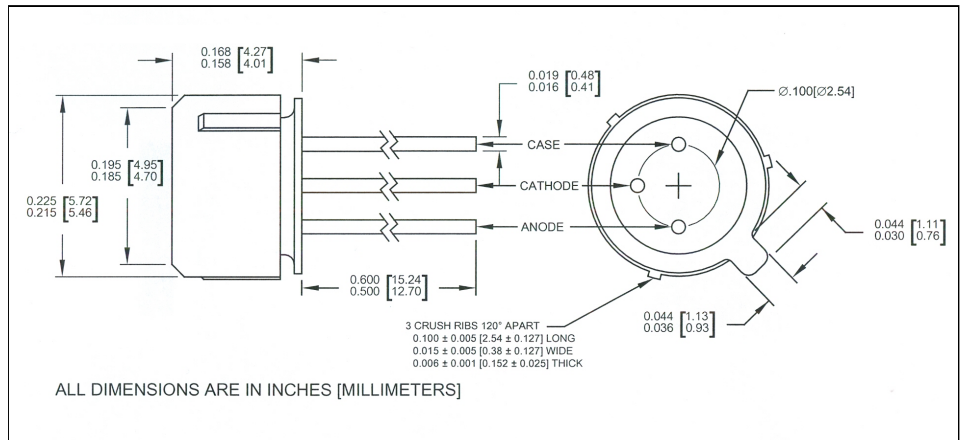
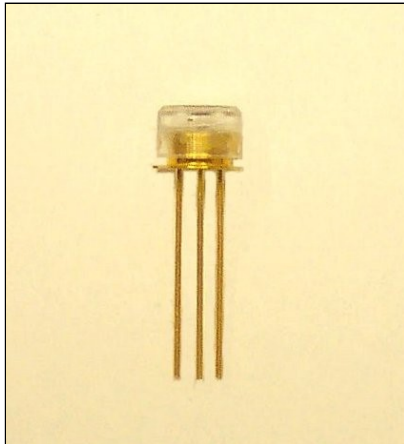

features

- High power output
- High speed
- Electrically isolated package
- Optimized for fiber-optic applications
- TO-18 header with plastic window
- RoHS compliant

description

The CFE370 series contain 850nm AlGaAs IREDS mounted on TO-18 headers. The devices are designed to self-align in the 0.228" (5.79 mm) bore of a standard fiber-optic receptacle. Three crush ribs on the outside of the case provide press-fit installation and precise alignment.

absolute maximum ratings ($T_A = 25^\circ\text{C}$ unless otherwise stated)

storage temperature.....	-55°C to +115°C
operating temperature.....	-40°C to +100°C
lead soldering temperature ⁽¹⁾	260°C
reverse voltage	1 V
continuous forward current ⁽²⁾	100 mA

notes:

1. 1/16" (1.6mm) from case for 5 seconds maximum.
2. Derate linearly 1.07 mA/°C from 25°C free air temperature to $T_A = +100^\circ\text{C}$.
3. The component must aligned with the 50/125 mm, N.A. = 0.20 fiber to achieve optimum coupling.
4. Pre-bias at 5mA.

electrical characteristics ($T_A = 25^\circ\text{C}$, $V_{CC} = 5\text{VDC}$ unless otherwise noted)

symbol	parameter		min	typ	max	units	test conditions
P_{T50} ⁽³⁾	Total coupled power	CFE370A	25	38	-	μW	$I_F = 100\text{ mA}$
		CFE370B	15	20	-		
		CFE370C	5	10	-		
V_F	Forward voltage		-	1.7	2.2	V	$I_F = 100\text{ mA}$
I_R	Reverse current				10	μA	$V_R = 2\text{ V}$
λ_P	Peak emission wavelength		-	850	-	nm	$I_F = 50\text{ mA}$
BW	Spectral bandwidth at half power points		-	35	-	nm	$I_F = 50\text{ mA}$
t_r	Output rise time		-	6.0	10	ns	$I_F = 100\text{ mA}$, 10% - 90% ⁽⁴⁾
t_f	Output fall time		-	6.0	10	ns	$I_F = 100\text{ mA}$, 90% - 10% ⁽⁴⁾

Clairex reserves the right to make changes at any time to improve design and to provide the best possible product.